

EENG 372

Introduction to digital Communications

Sampling-Quantization-Pulse modulation

By: Dr. Mohab Mangoud

Digital Communication

Q: What is Digital Communication ?

The transfer of information (analog or digital) using digital signals and techniques.

Q: What are digital signals?

Digital signals are binary pulse that have two distinct states, each represented by a voltage level.

The two levels are:

1. Binary 0 or low.
2. Binary 1 or high.

high

low

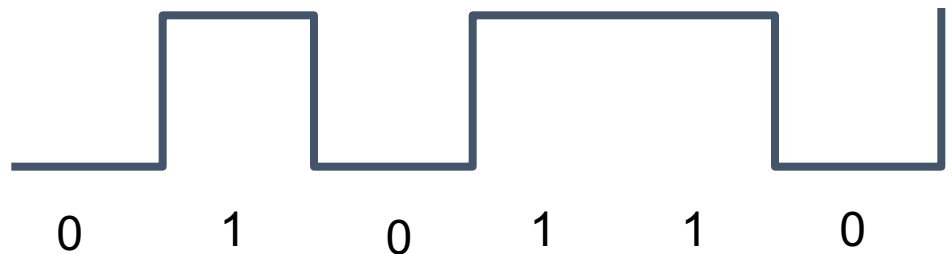

Digital Communication

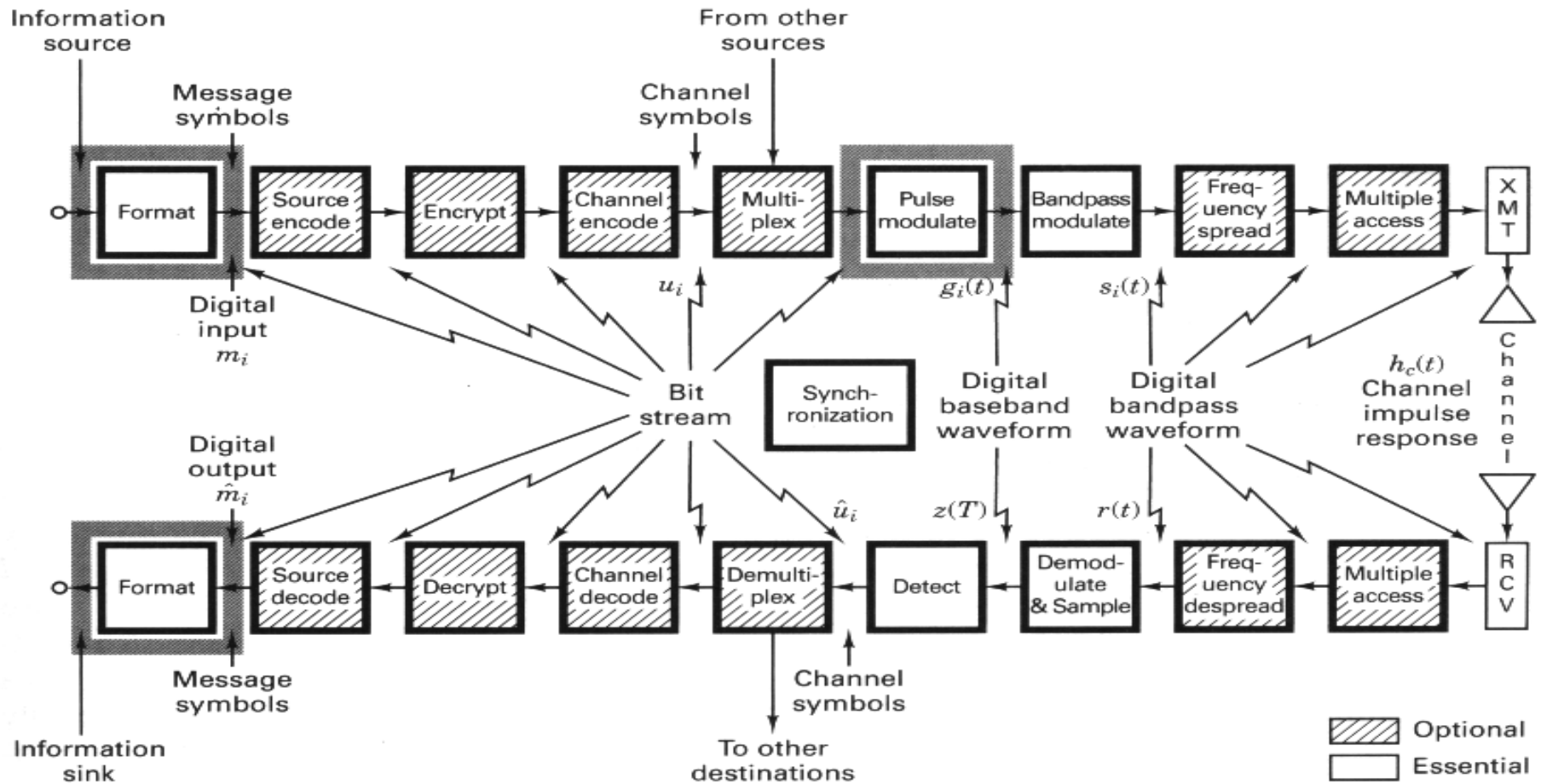

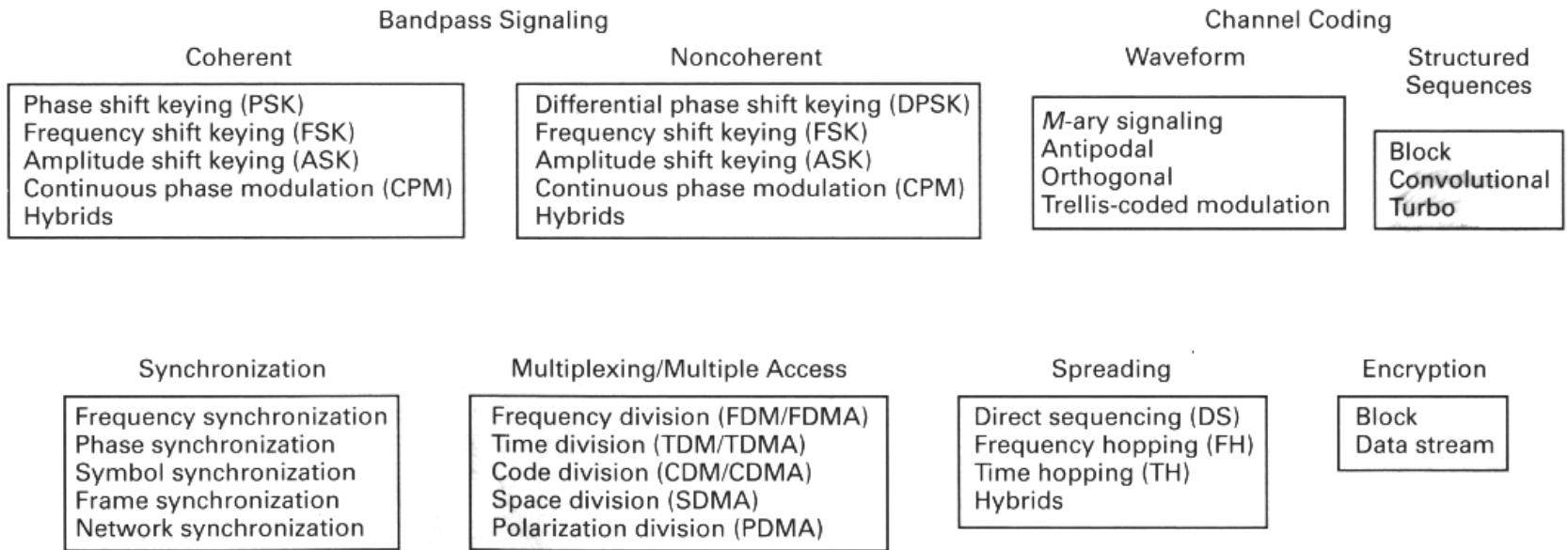
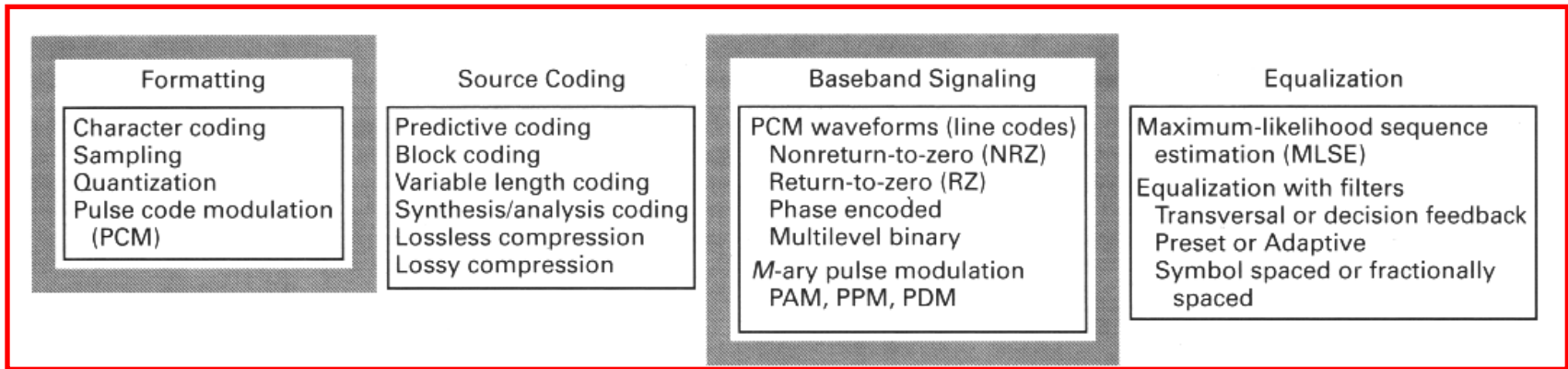
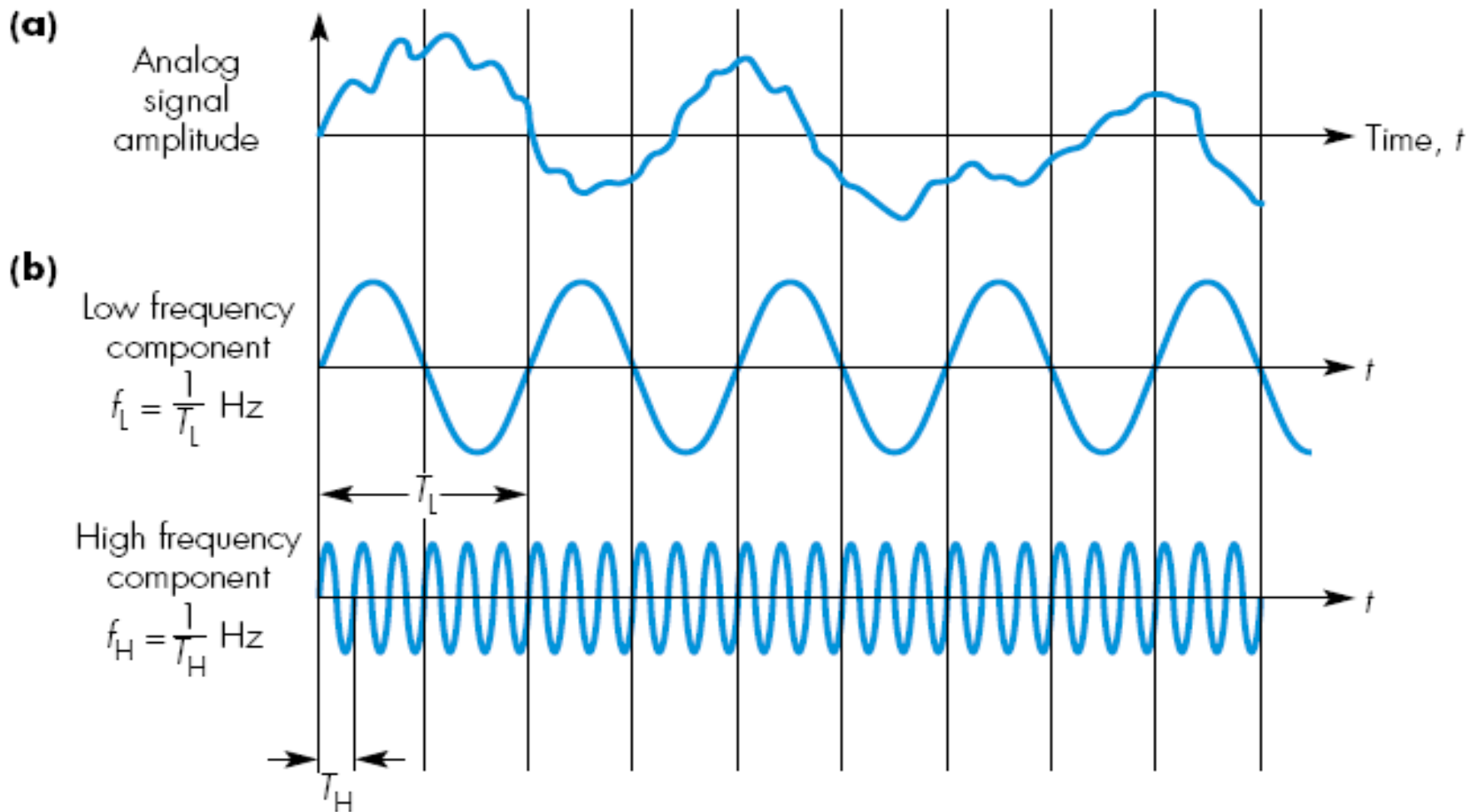

Figure 2.1 Basic digital communication transformations

Digitization principles

- The conversion of an analog signal into a digital form
- signal encoder.
- signal decoder.

Signal properties: (a) time-varying analog signal;
(b) sinusoidal frequency components;



$T_{L/H}$ = time for one cycle = signal period

Signal properties: (c) signal bandwidth examples; (d) effect of a limited bandwidth transmission channel.

(c)

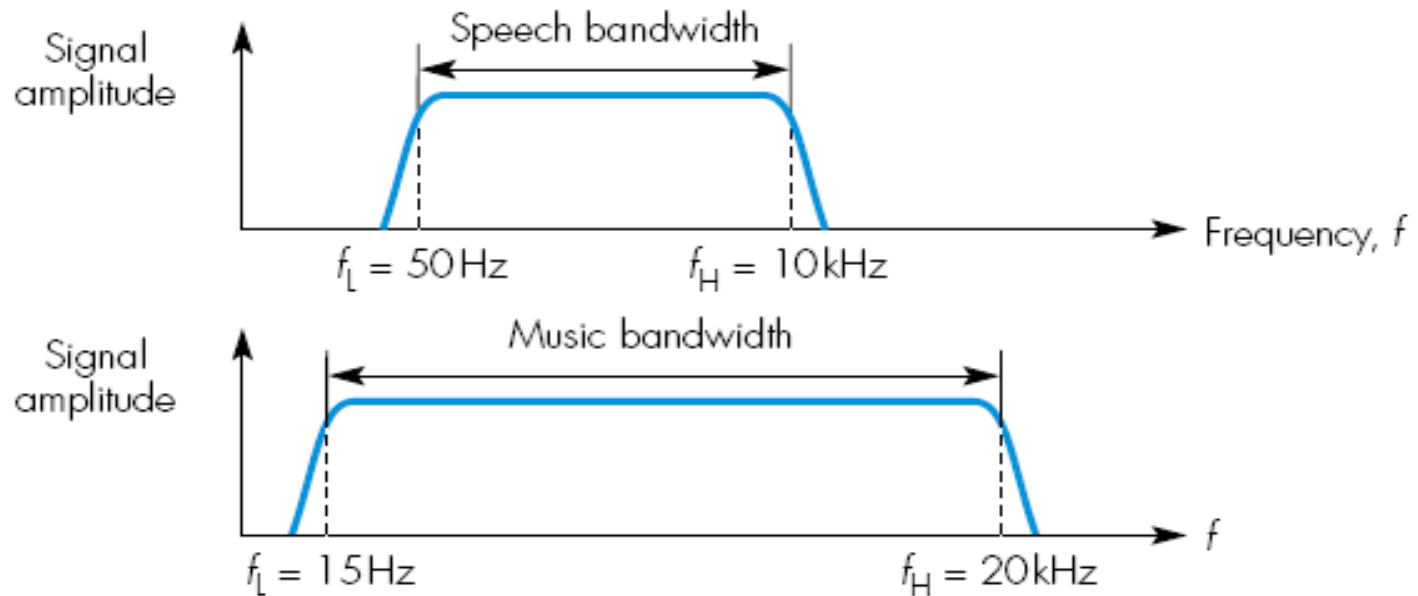

(d)

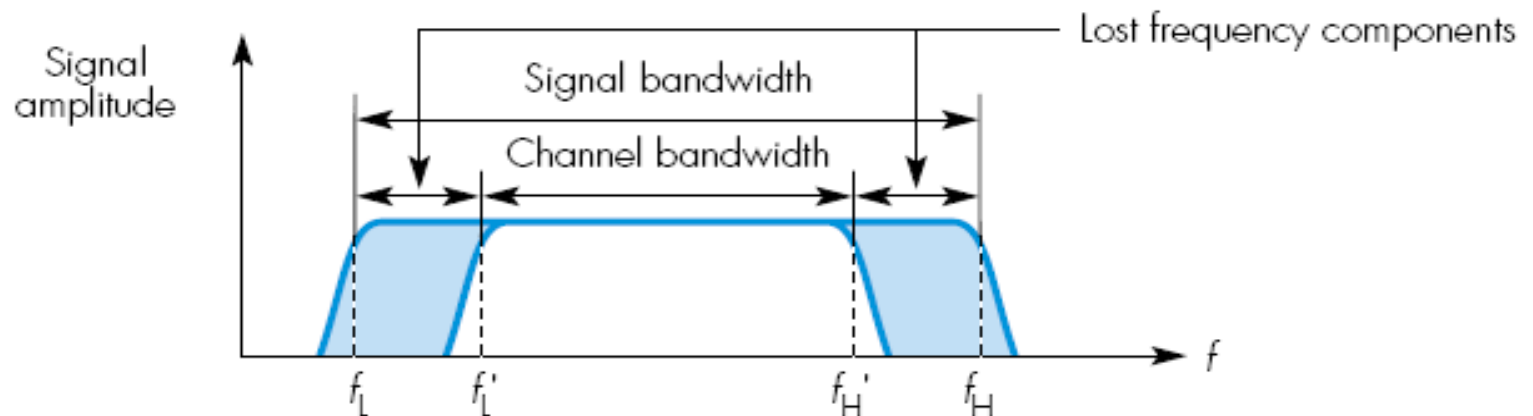

f'_L and f'_H are known as the cut off frequencies of the channel

Signal Encoder Design: Circuit Components

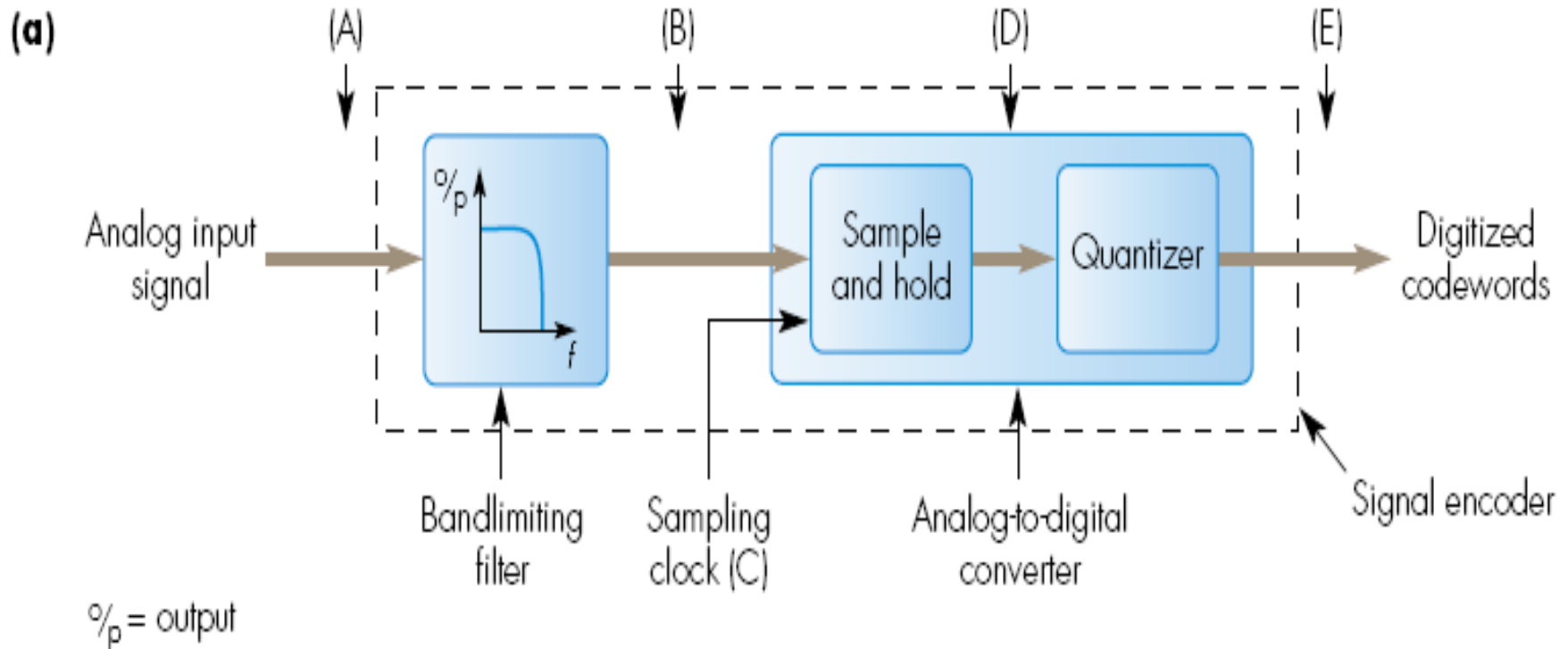

Signal Encoder Design: Associated Waveform Set

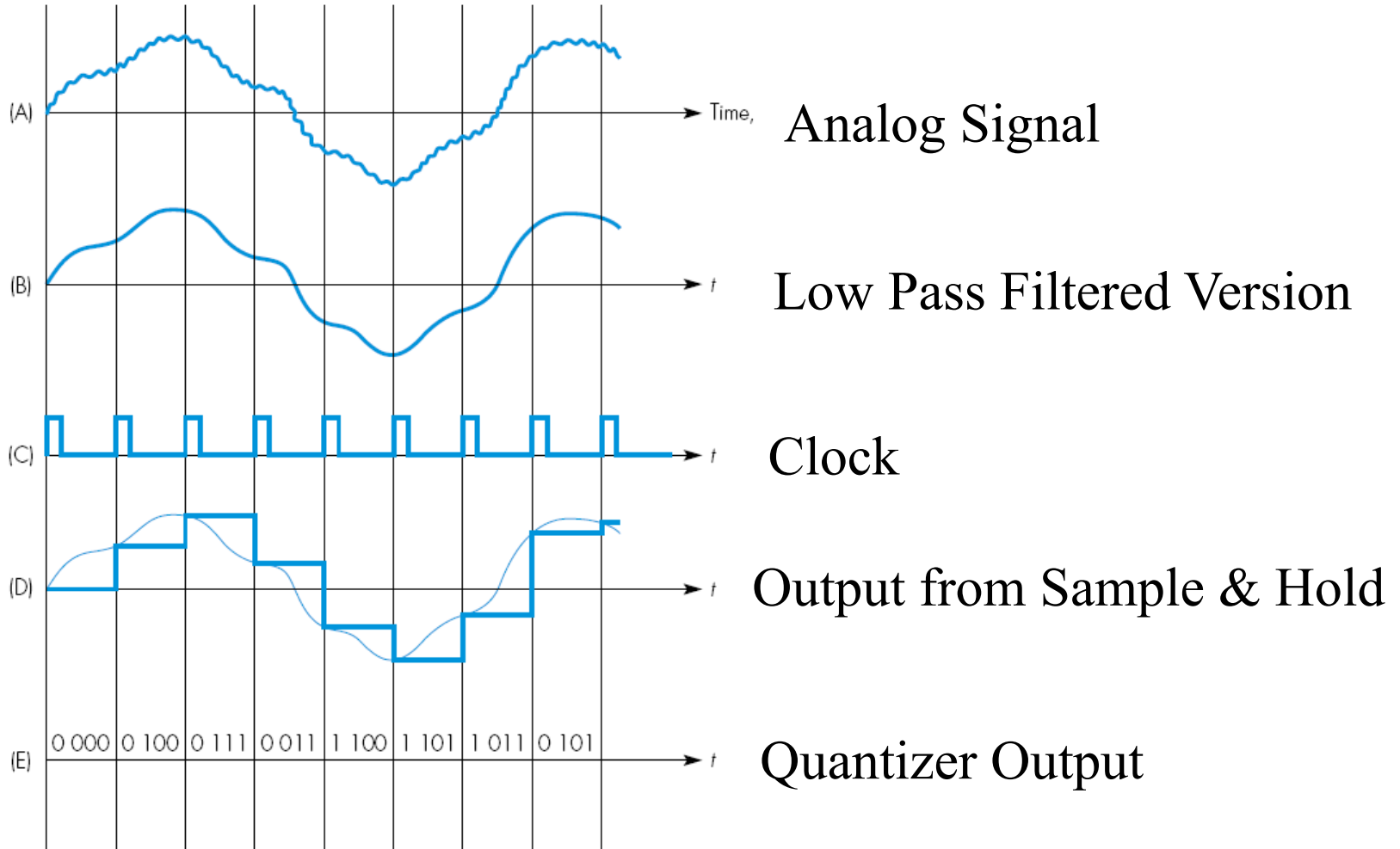

Alias Signal Generation Due to Under Sampling

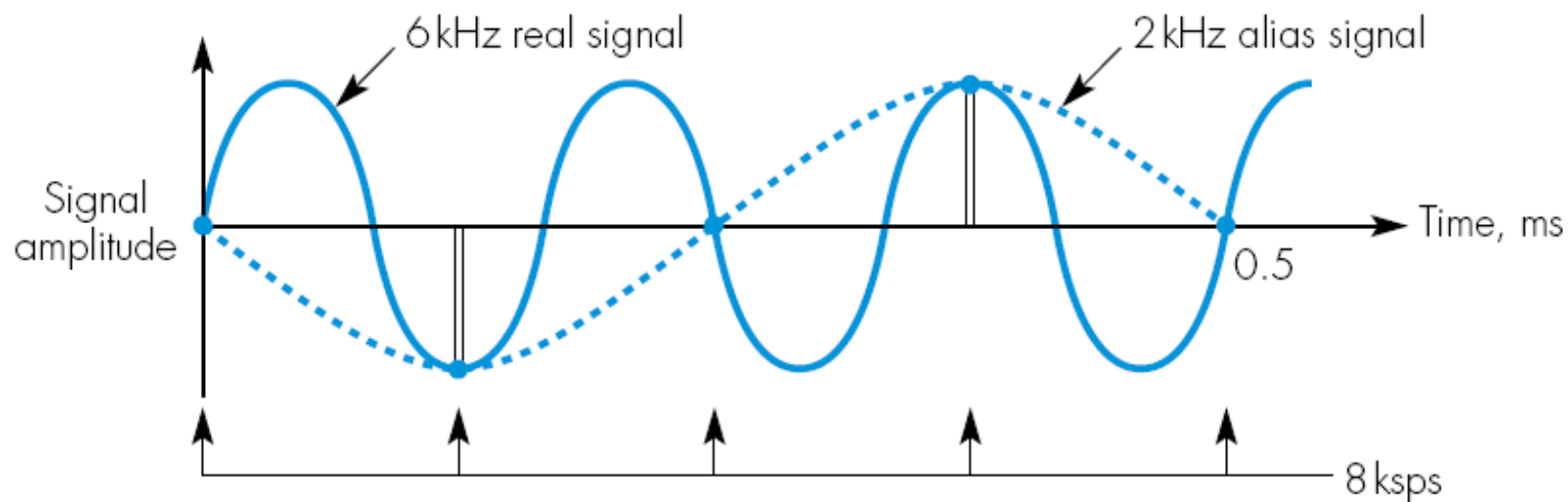

Determine the rate of the sampler and the bandwidth of the bandlimiting filter in an encoder which is to be used for the digitization of an analog signal which has a bandwidth from 15 Hz through to 10 kHz assuming the digitized signal:

- (i) is to be stored within the memory of a computer,
- (ii) is to be transmitted over a channel which has a bandwidth from 200 Hz through to 3.4 kHz.

Answer:

The Nyquist sampling rate must be at least twice the highest frequency component of the signal or transmission channel. Hence:

- (i) The sampling rate must be at least $2 \times 10 \text{ kHz} = 20 \text{ kHz}$ or 20 ksp/s and the bandwidth of the bandlimiting filter is from 0 Hz through to 10 kHz.
- (ii) The sampling rate must be at least $2 \times 3.4 \text{ kHz} = 6.8 \text{ kHz}$ or 6.8 ksp/s and the bandwidth of the bandlimiting filter is from 0 Hz through to 3.4 kHz.

In practice, it should be noted that, because of imperfections in filters, some higher frequency components above the filter cut-off frequency may be passed and hence the sampling rate is normally higher than the two derived values. In the case of (ii), for example, it is common to assume that frequency components of up to 4 kHz may be passed by the bandlimiting filter and hence a sampling rate of 8 ksp/s is normally used.

2.4 FORMATTING ANALOG INFORMATION

If the information is analog, it cannot be character encoded as in the case of textual data; the information must first be transformed into a digital format. The process of transforming an analog waveform into a form that is compatible with a digital communication system starts with sampling the waveform to produce a discrete pulse-amplitude-modulated waveform, as described below.

2.4.1 The Sampling Theorem

The link between an analog waveform and its sampled version is provided by what is known as the sampling process. This process can be implemented in several ways, the most popular being the sample-and-hold operation. In this operation, a switch and storage mechanism (such as a transistor and a capacitor, or a shutter and a filmstrip) form a sequence of samples of the continuous input waveform. The output of the sampling process is called *pulse amplitude modulation* (PAM) because the successive output intervals can be described as a sequence of pulses with amplitudes derived from the input waveform samples. The analog waveform can be approximately retrieved from a PAM waveform by simple low-pass filtering. An important question: how closely can a filtered PAM waveform approximate the original input waveform? This question can be answered by reviewing the *sampling theorem*, which states the following [1]: A bandlimited signal having no spectral components above f_m hertz can be determined uniquely by values sampled at uniform intervals of

$$T_s \leq \frac{1}{2f_m} \text{ sec} \quad (2.1)$$

This particular statement is also known as the *uniform sampling theorem*. Stated another way, the upper limit on T_s can be expressed in terms of the sampling rate, denoted $f_s = 1/T_s$. The restriction, stated in terms of the sampling rate, is known as the *Nyquist criterion*. The statement is

$$f_s \geq 2f_m \quad (2.2)$$

The sampling rate $f_s = 2f_m$ is also called the *Nyquist rate*. The Nyquist criterion is a theoretically sufficient condition to allow an analog signal to be *reconstructed completely* from a set of uniformly spaced discrete-time samples. In the sections that follow, the validity of the sampling theorem is demonstrated using different sampling approaches.

2.4.1.1 Impulse Sampling

Here we demonstrate the validity of the sampling theorem using the frequency convolution property of the Fourier transform. Let us first examine the case of *ideal sampling* with a sequence of unit impulse functions. Assume an analog waveform, $x(t)$, as shown in Figure 2.6a, with a Fourier transform, $X(f)$, which is zero outside the interval $(-f_m < f < f_m)$, as shown in Figure 2.6b. The sampling of $x(t)$ can be viewed as the product of $x(t)$ with a periodic train of unit impulse functions $x_\delta(t)$, shown in Figure 2.6c and defined as

$$x_\delta(t) = \sum_{n=-\infty}^{\infty} \delta(t - nT_s) \quad (2.3)$$

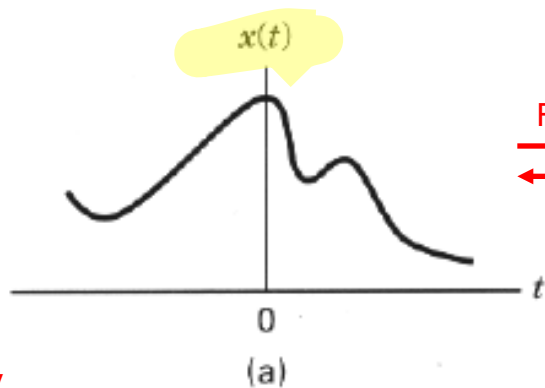

Fourier Transform
 \longleftrightarrow

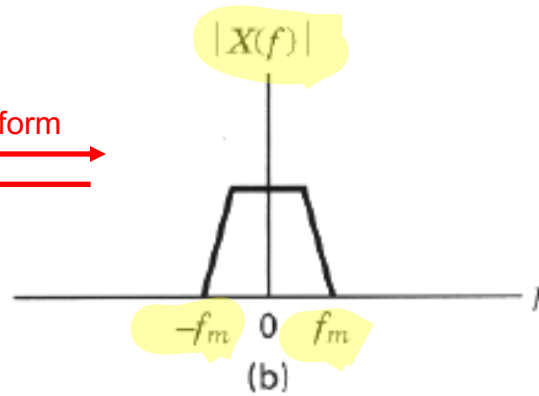

Multiply
in time

Convolution
in Frequency

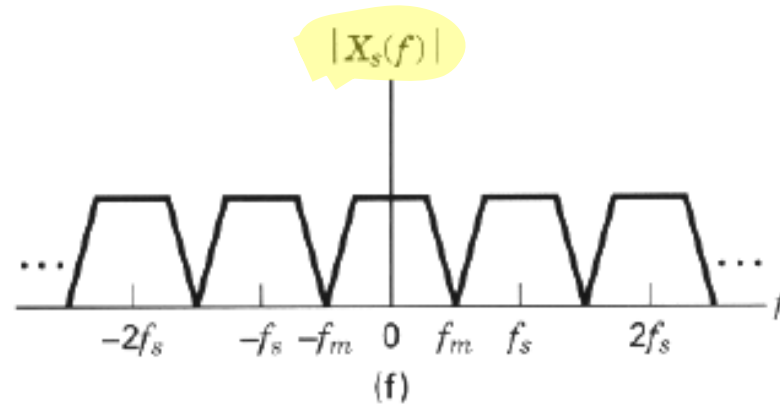
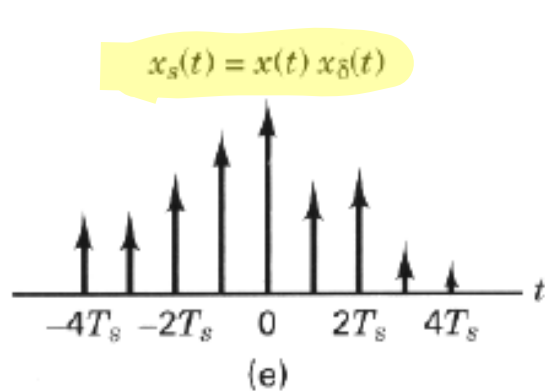
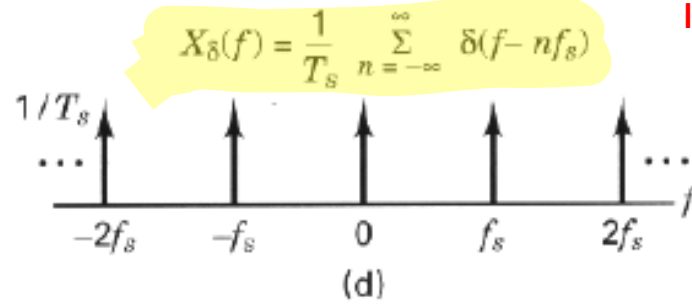
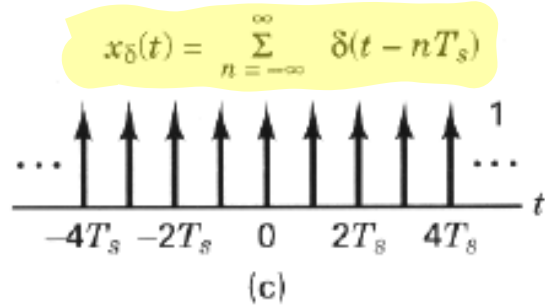

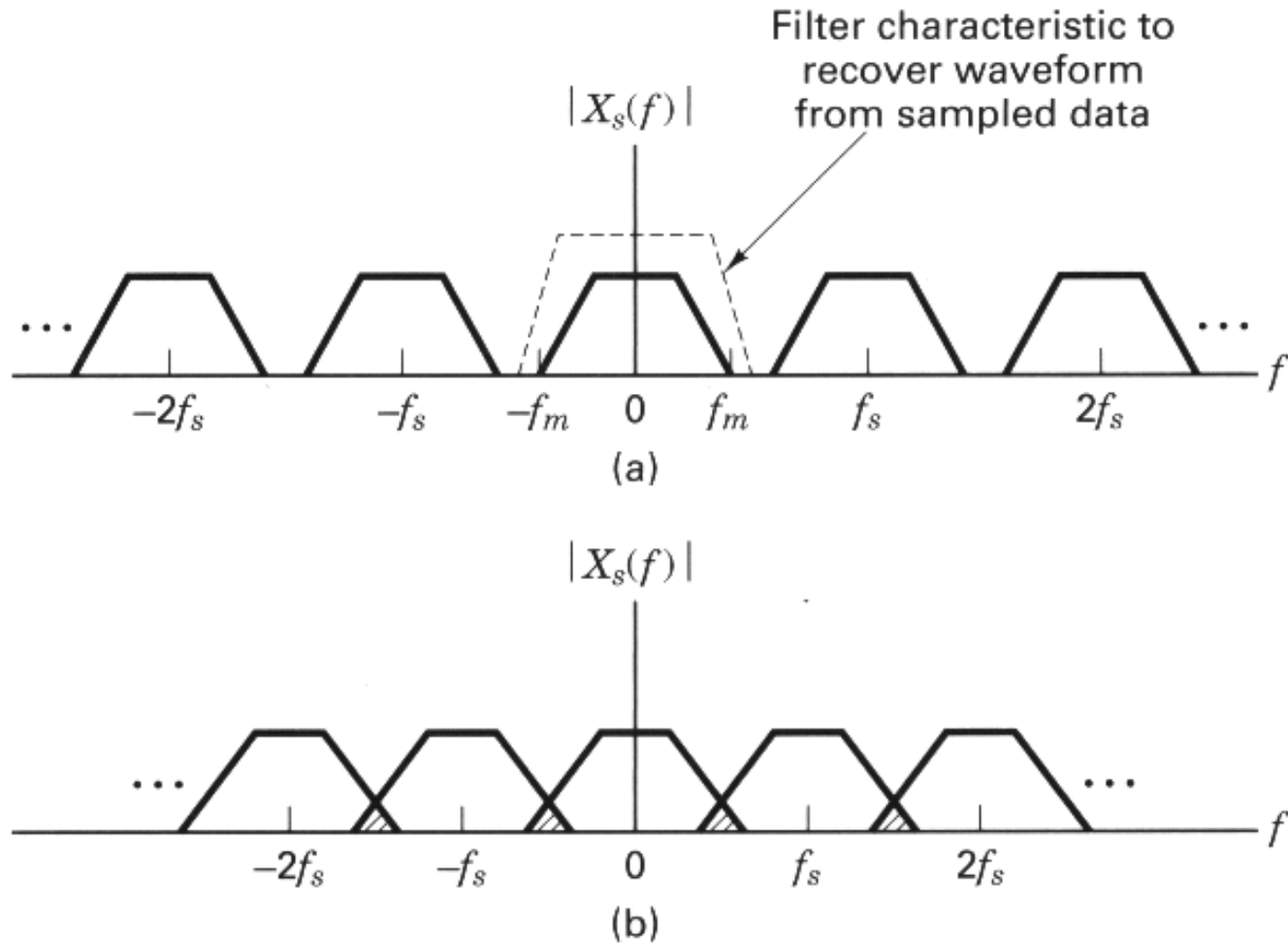

Figure 2.7 Spectra for various sampling rates. (a) Sampled spectrum ($f_s > 2f_m$). (b) Sampled spectrum ($f_s < 2f_m$).

this we mean that a bandwidth can be determined beyond which the spectral components are attenuated to a level that is considered negligible.

2.4.1.2 Natural Sampling

Here we demonstrate the validity of the sampling theorem using the frequency shifting property of the Fourier transform. Although instantaneous sampling is a convenient model, a more practical way of accomplishing the sampling of a bandlimited analog signal $x(t)$ is to multiply $x(t)$, shown in Figure 2.8a, by the pulse train or switching waveform $x_p(t)$, shown in Figure 2.8c. Each pulse in $x_p(t)$ has width T and amplitude $1/T$. Multiplication by $x_p(t)$ can be viewed as the opening and closing of a switch. As before, the sampling frequency is designated f_s , and its reciprocal, the time period between samples, is designated T_s . The resulting sampled-data sequence, $x_s(t)$, is illustrated in Figure 2.8e and is expressed as

$$x_s(t) = x(t)x_p(t) \quad (2.9)$$

The sampling here is termed *natural sampling*, since the top of each pulse in the $x_s(t)$ sequence retains the shape of its corresponding analog segment during the pulse interval. Using Equation (A.13), we can express the periodic pulse train as a Fourier series in the form

$$x_p(t) = \sum_{n=-\infty}^{\infty} c_n e^{j 2\pi n f_s t} \quad (2.10)$$

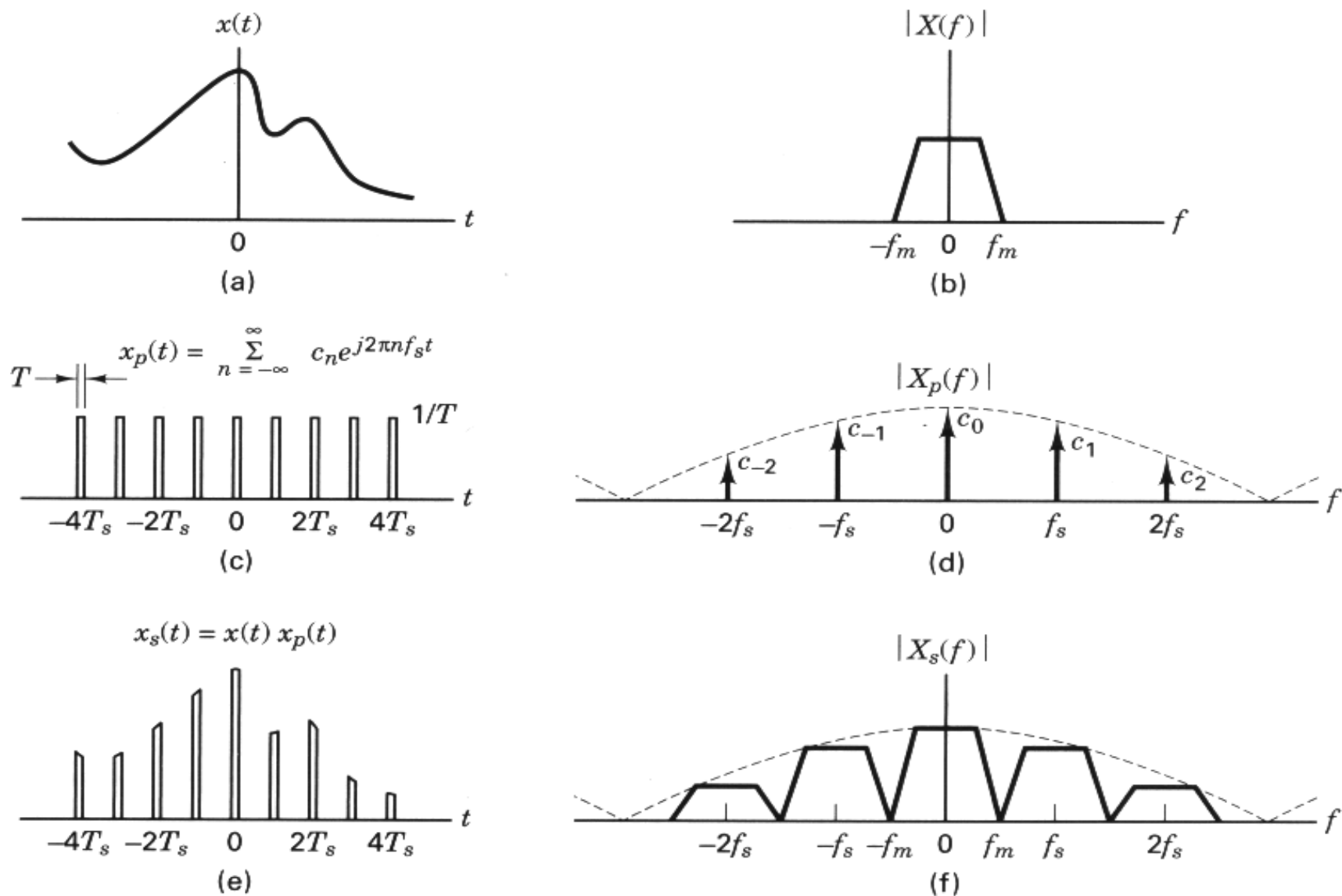

Figure 2.8 Sampling theorem using the frequency shifting property of the Fourier transform.

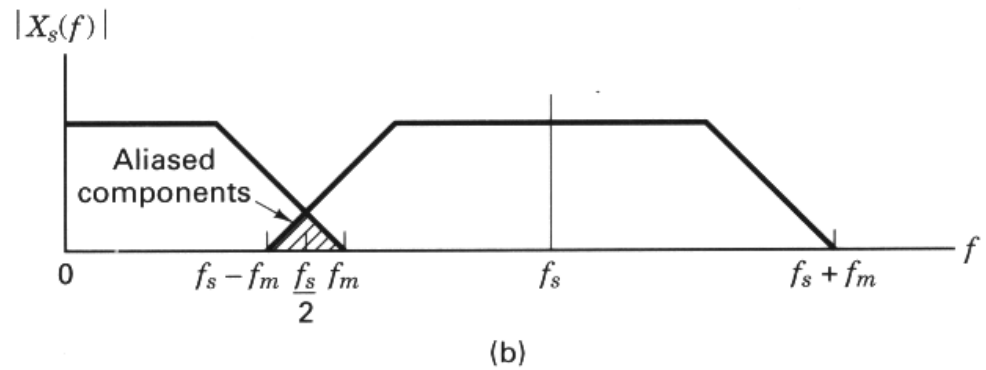
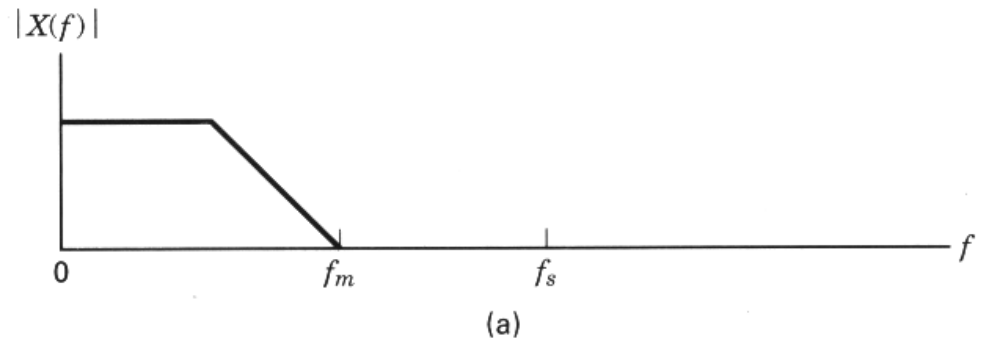

Figure 2.9 Aliasing in the frequency domain. (a) Continuous signal spectrum. (b) Sampled signal spectrum.

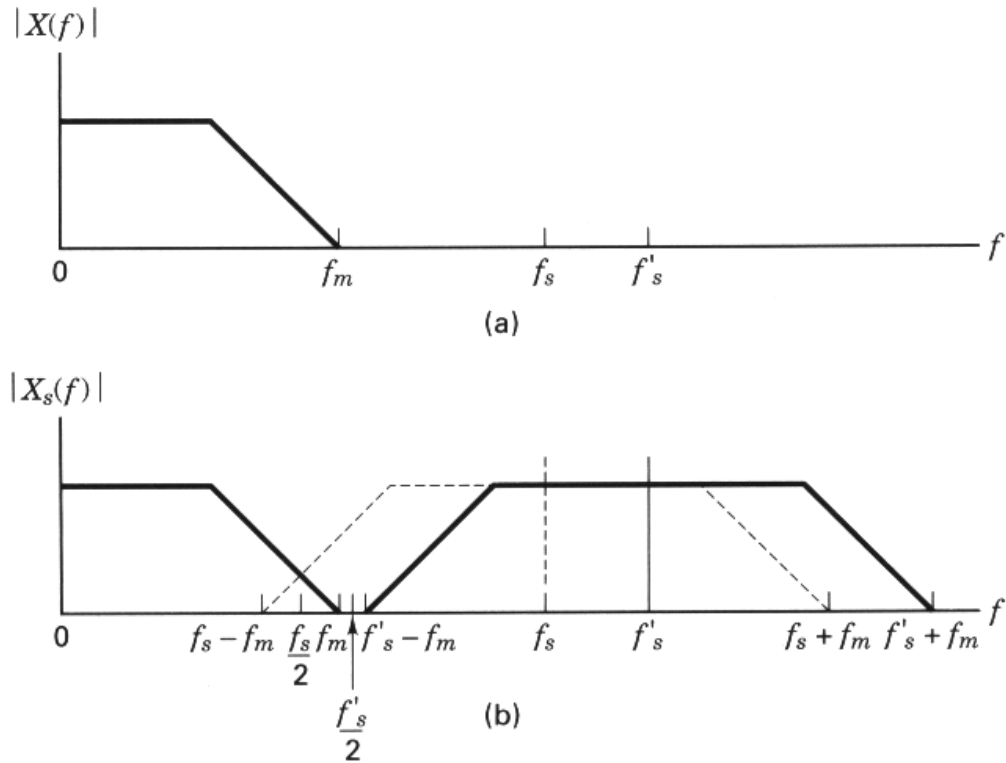

Figure 2.10 Higher sampling rate eliminates aliasing. (a) Continuous signal spectrum. (b) Sampled signal spectrum.

2.4.4 Signal Interface for a Digital System

Let us examine four ways in which analog source information can be described. Figure 2.14 illustrates the choices. Let us refer to the waveform in Figure 2.14a as the *original analog waveform*. Figure 2.14b represents a sampled version of the original waveform, typically referred to as *natural-sampled data* or *PAM (pulse amplitude modulation)*. Do you suppose that the sampled data in Figure 2.14b are compatible with a digital system? No, they are not, because the amplitude of each natural sample still has an infinite number of possible values; a digital system deals with a finite number of values. Even if the sampling is flat-top sampling, the possible pulse values form an infinite set, since they reflect all the possible values of the continuous analog waveform. Figure 2.14c illustrates the original waveform represented by discrete pulses. Here the pulses have flat tops *and* the pulse amplitude values are limited to a finite set. Each pulse is expressed as a level from a finite number of predetermined levels; each such level can be represented by a symbol from a finite alphabet. The pulses in Figure 2.14c are referred to as *quantized samples*; such a format is the obvious choice for interfacing with a digital system. The format in Figure 2.14d may be construed as *the output of a sample-and-hold circuit*. When the sample values are quantized to a finite set, this format can also interface with a digital system. After quantization, the analog waveform can still be recovered, but not precisely; improved reconstruction fidelity of the analog waveform can be achieved by *increasing the number of quantization levels (requiring increased system bandwidth)*. Signal distortion due to quantization is treated in the following sections (and later in

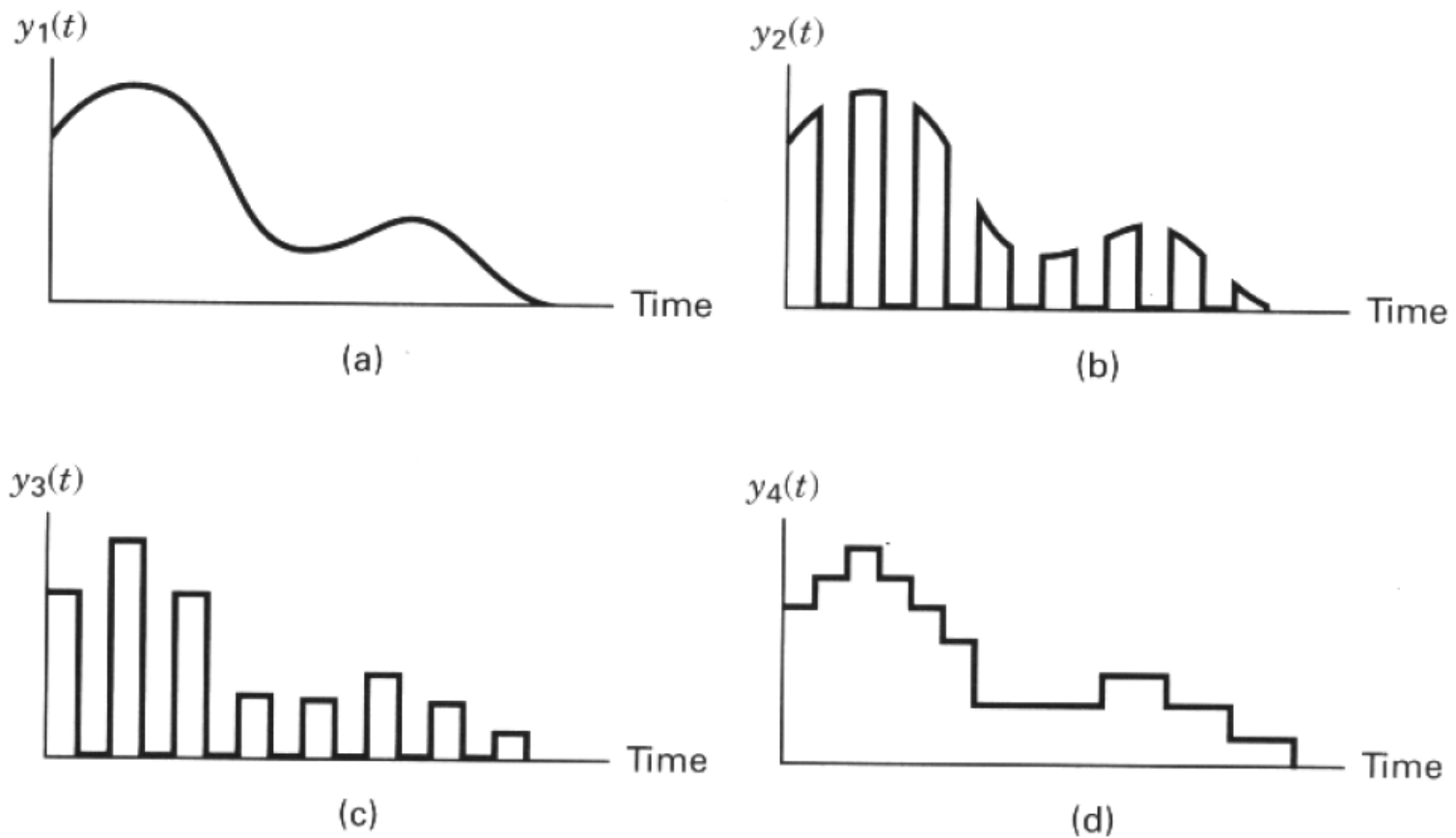
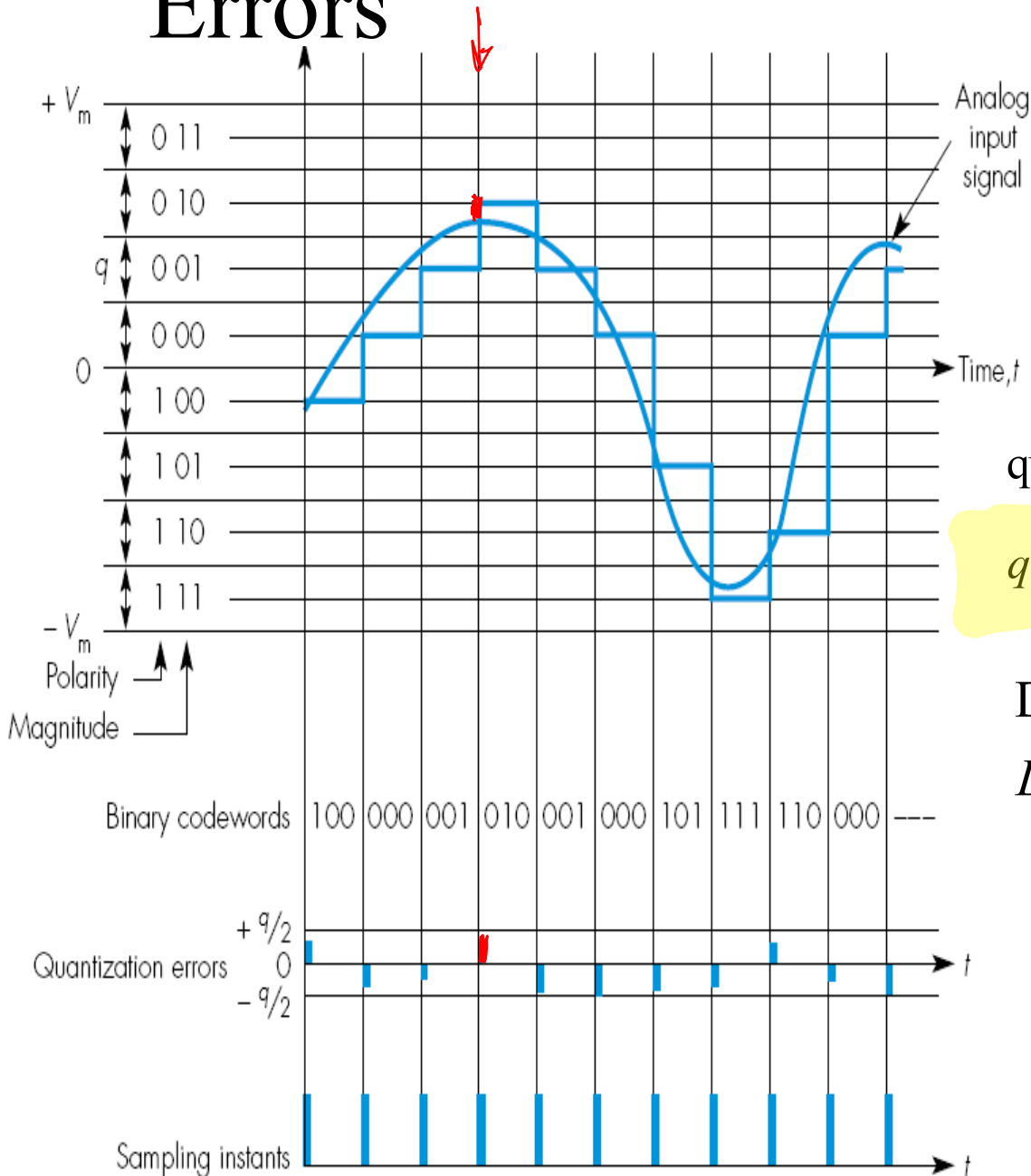

Figure 2.14 Amplitude and time coordinates of source data. (a) Original analog waveform. (b) Natural-sampled data. (c) Quantized samples. (d) Sample and hold.

Quantization Procedure: Source of Errors



quantization interval q

$$q = \frac{2V_{\max}}{2^n} \text{ where } n = \text{number of bits}$$

Dynamic Range D in Decibels

$$D = 20 \log_{10} (V_{\max} / V_{\min}) \text{ dB}$$

Signal Decoder Design: Associated Waveform Set

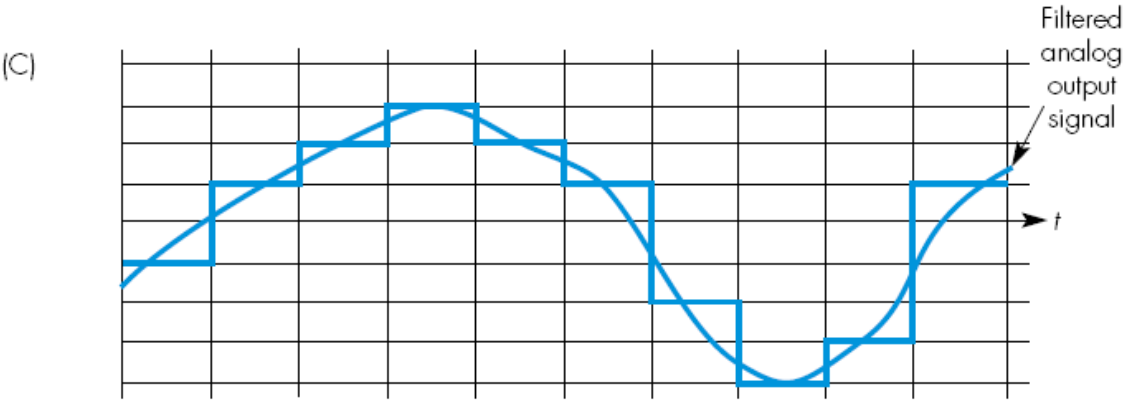
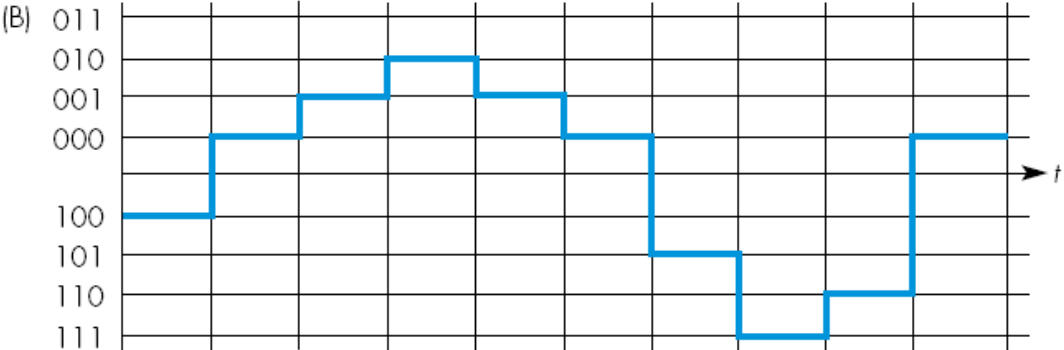
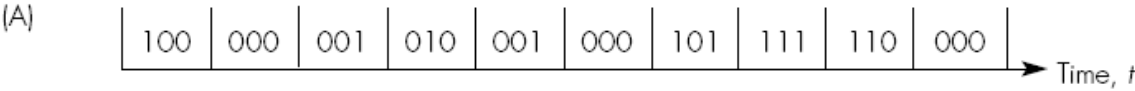

2.6 PULSE CODE MODULATION

Pulse code modulation (PCM) is the name given to the class of baseband signals obtained from the quantized PAM signals by encoding each quantized sample into a *digital word* [3].

The source information is sampled and quantized to one of L levels; then each quantized sample is digitally encoded into an ℓ -bit ($\ell = \log_2 L$) codeword. For baseband transmission, the codeword bits will then be transformed to pulse waveforms. The essential features of binary PCM are shown in Figure 2.16. Assume that an analog signal $x(t)$ is limited in its excursions to the range -4 to $+4$ V. The step size between quantization levels has been set at 1 V. Thus, eight quantization levels are employed; these are located at $-3.5, -2.5, \dots, +3.5$ V. We assign the code number 0 to the level at -3.5 V, the code number 1 to the level at -2.5 V, and so on, until the level at 3.5 V, which is assigned the code number 7. Each code number has its representation in binary arithmetic, ranging from 000 for code number 0 to 111 for code number 7. Why have the voltage levels been chosen in this manner, compared with using a sequence of consecutive integers, 1, 2, 3, \dots ? The choice of voltage levels is guided by two constraints. First, the quantile intervals between the levels should be equal; and second, it is convenient for the levels to be symmetrical about zero.

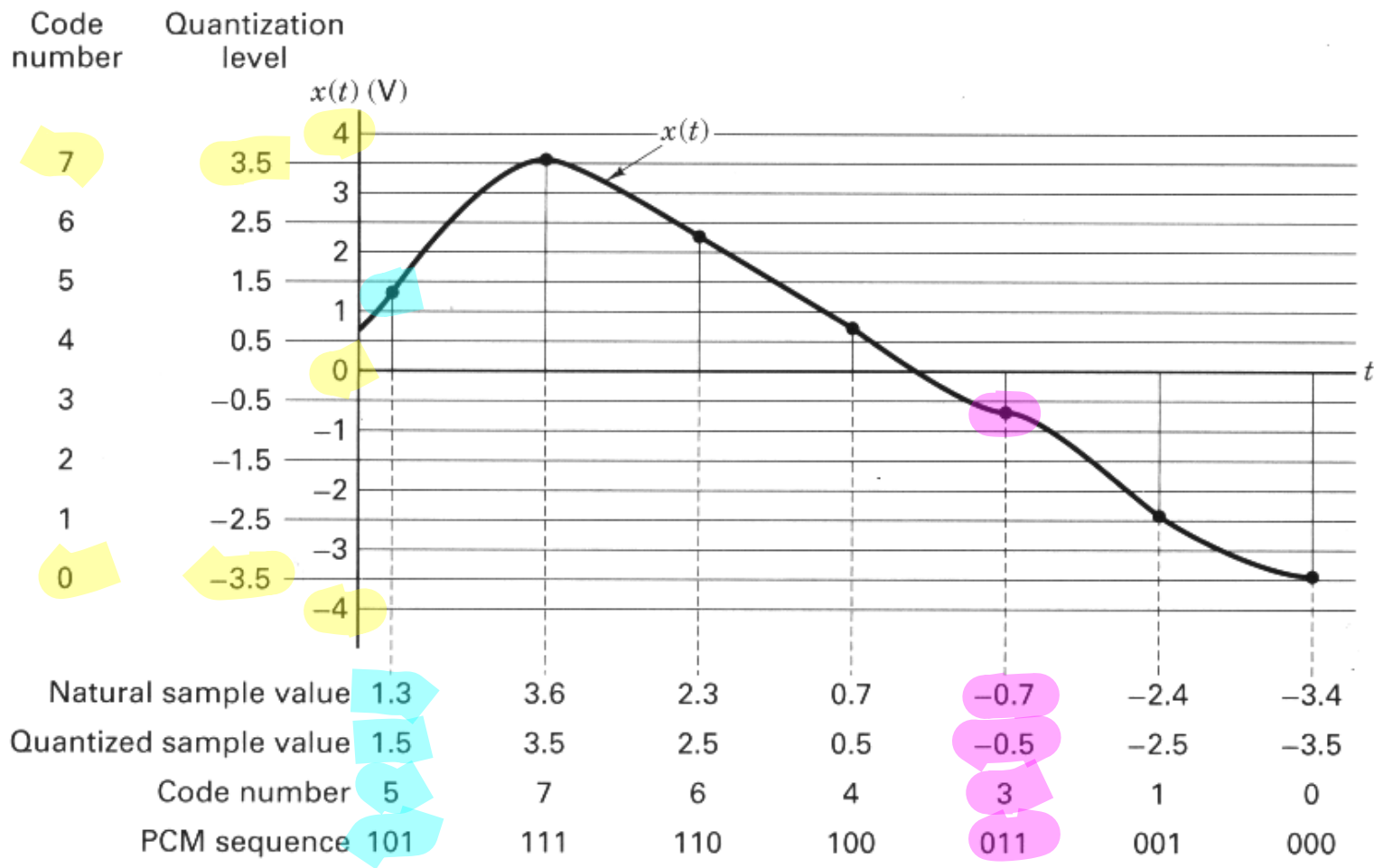
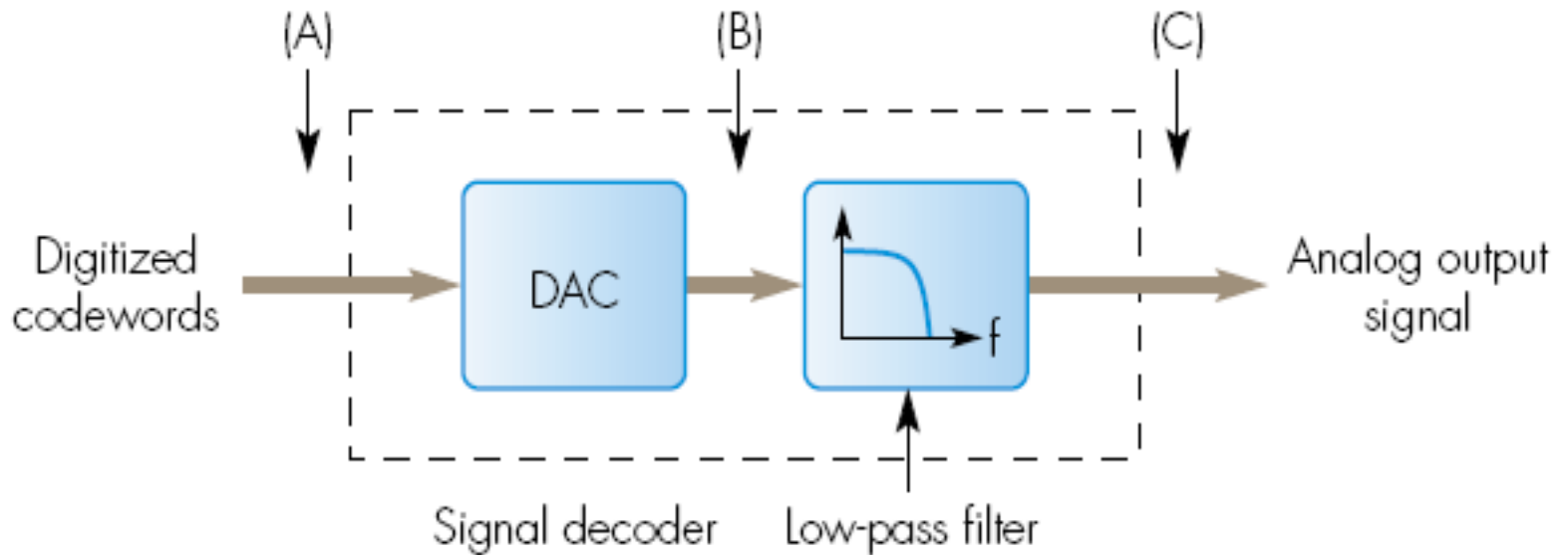

Figure 2.16 Natural samples, quantized samples, and pulse code modulation. (Reprinted with permission from Taub and Schilling, *Principles of Communications Systems*, McGraw-Hill Book Company, New York, 1971, Fig. 6.5-1, p. 205.)

Signal Decoder Design: Circuit Components



Extra Material (For reading)

Pulse Modulation

By: Dr. Sana Almansori

Pulse Modulation

Q: What is Pulse Modulation?

In a pulse modulation system, samples of the message signal are used to vary parameters of a pulse waveform:

1. The information signal is sampled
2. The samples are used to vary the amplitude, width or position of a pulse.

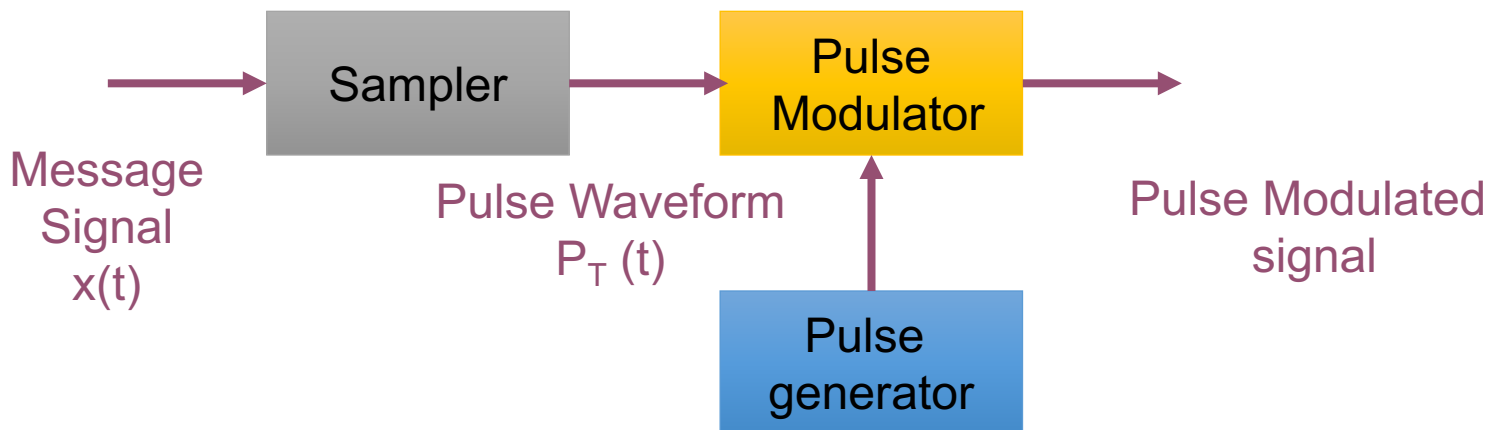

Pulse Modulation

Q: What are the different types of Pulse Modulation?

There are three types of pulse Modulation:

1. Pulse Amplitude Modulation (PAM):

The amplitude of the pulse is proportional to the message signal.

2. Pulse Width Modulation (PWM):

The width of the pulse is proportional to the message signal.

3. Pulse Position Modulation (PPM):

The position of the pulse is proportional to the message signal.

Sampling

Q: What is sampling?

Sampling is taking a sample of the message or information signal:

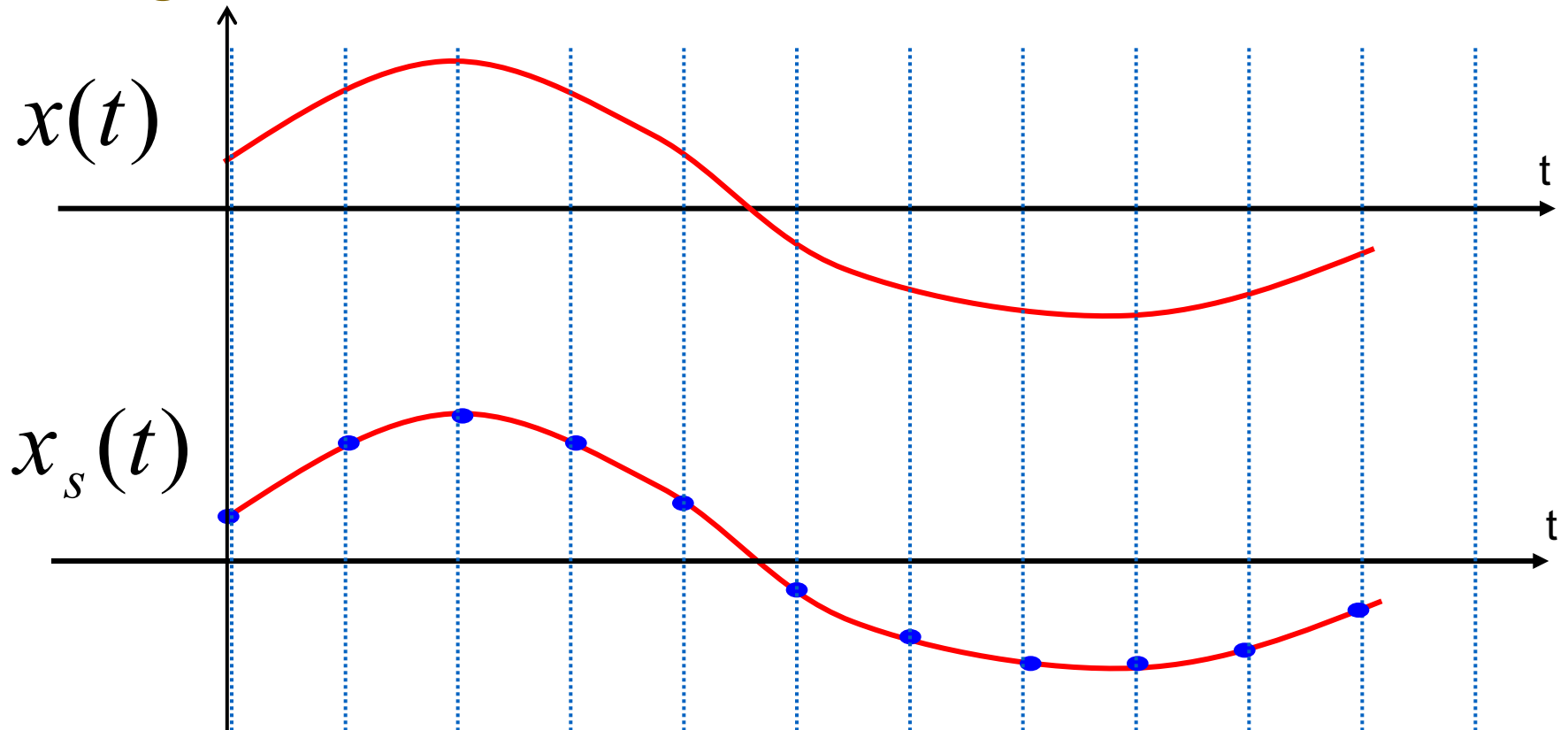

PAM

Q: How is PAM done?

Assume we have a message signal $x(t)$

If it is multiplied by a pulse train $p_T(t)$

We get a pulse amplitude modulated signal $x_{PAM}(t)$

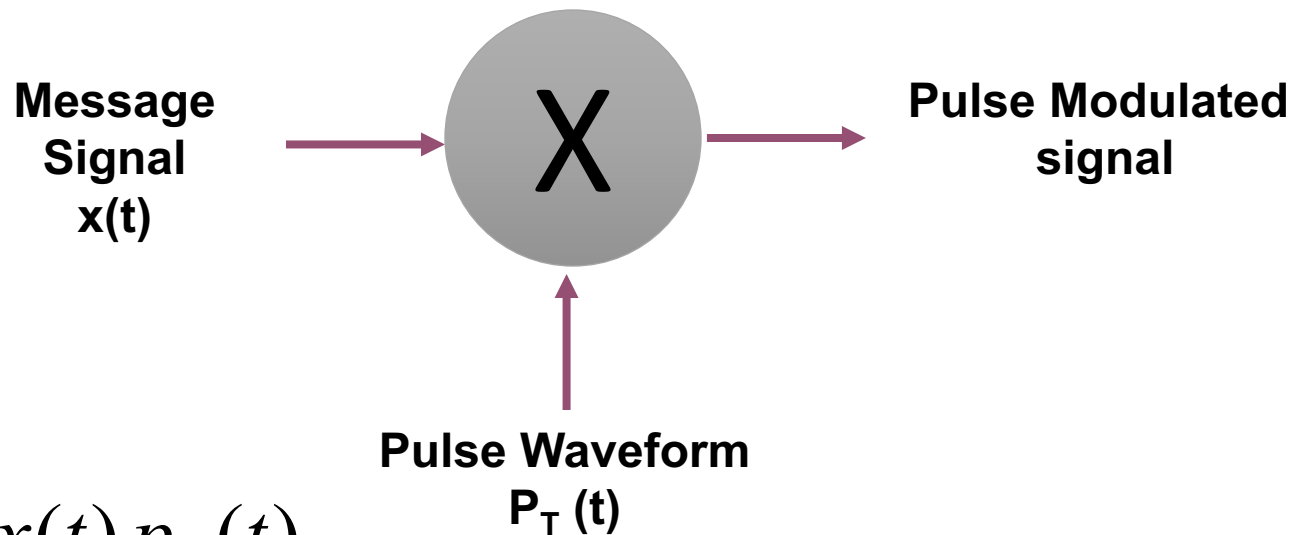

$$x_{PAM}(t) = x(t)p_T(t)$$

$$x_1(t) = 5 \cos(2\pi t)$$

modulating (message) signal

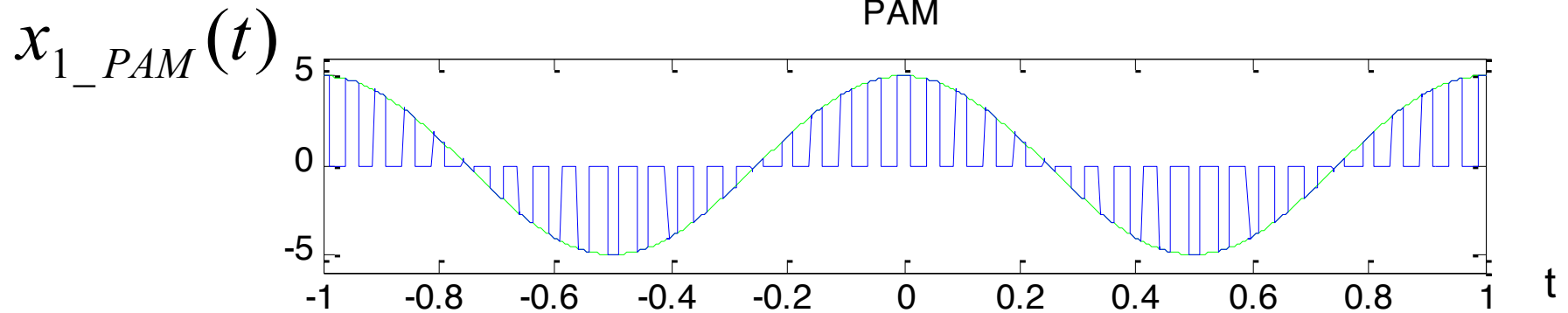
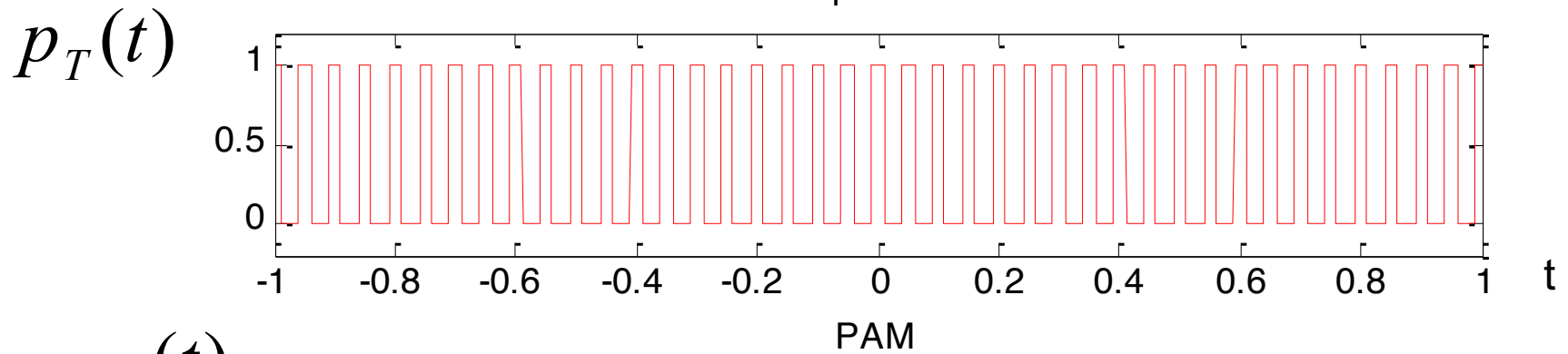
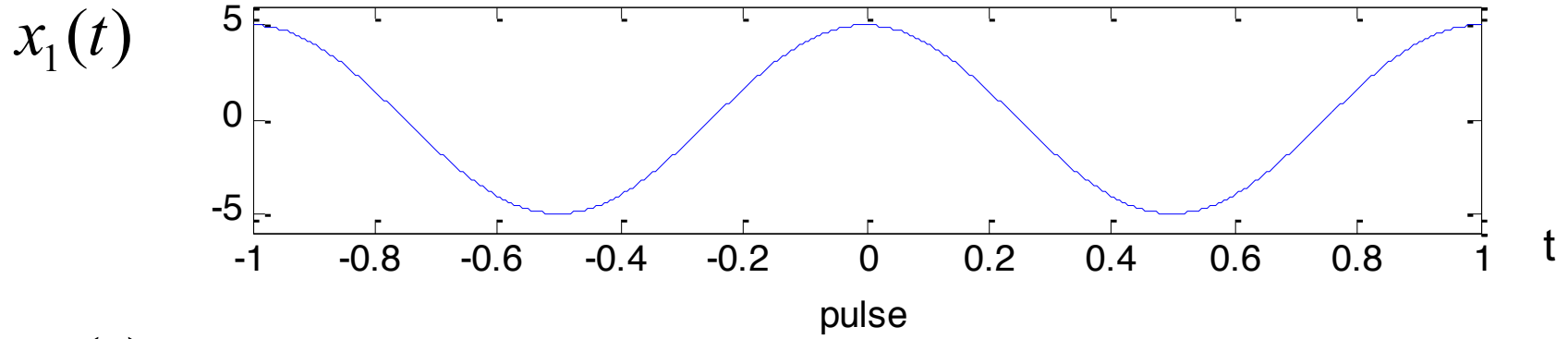

$$x_2(t) = 5(\cos(2\pi t) + \sin(4\pi t))$$

modulating (message) signal

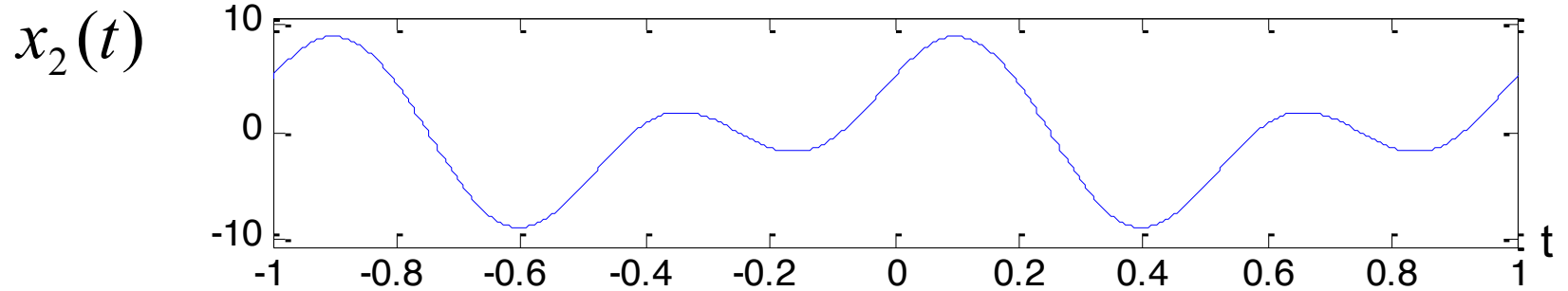

pulse

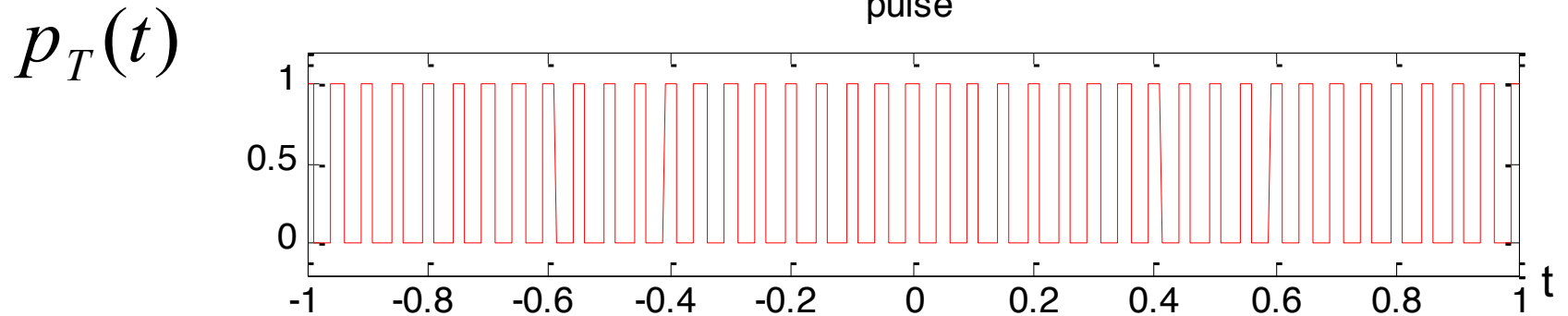

PAM

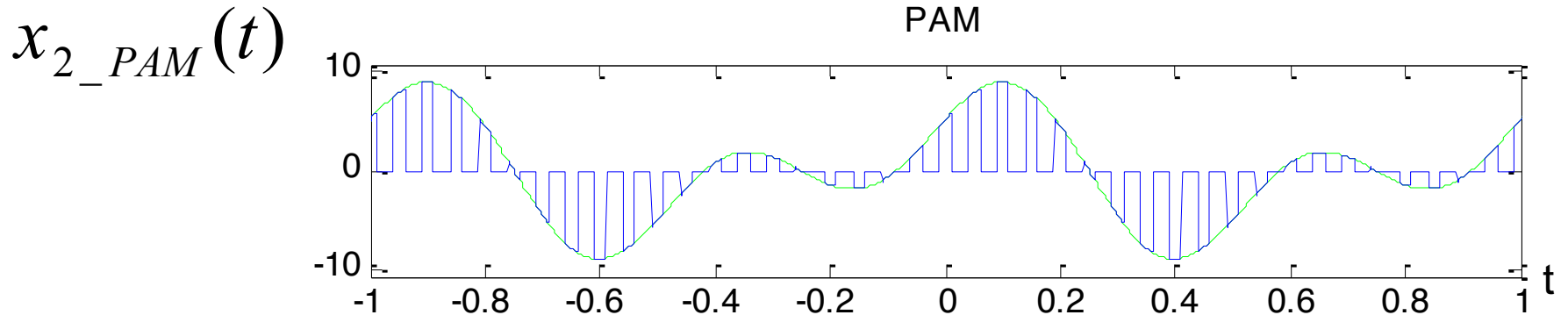

PWM

Q: How is PWM done?

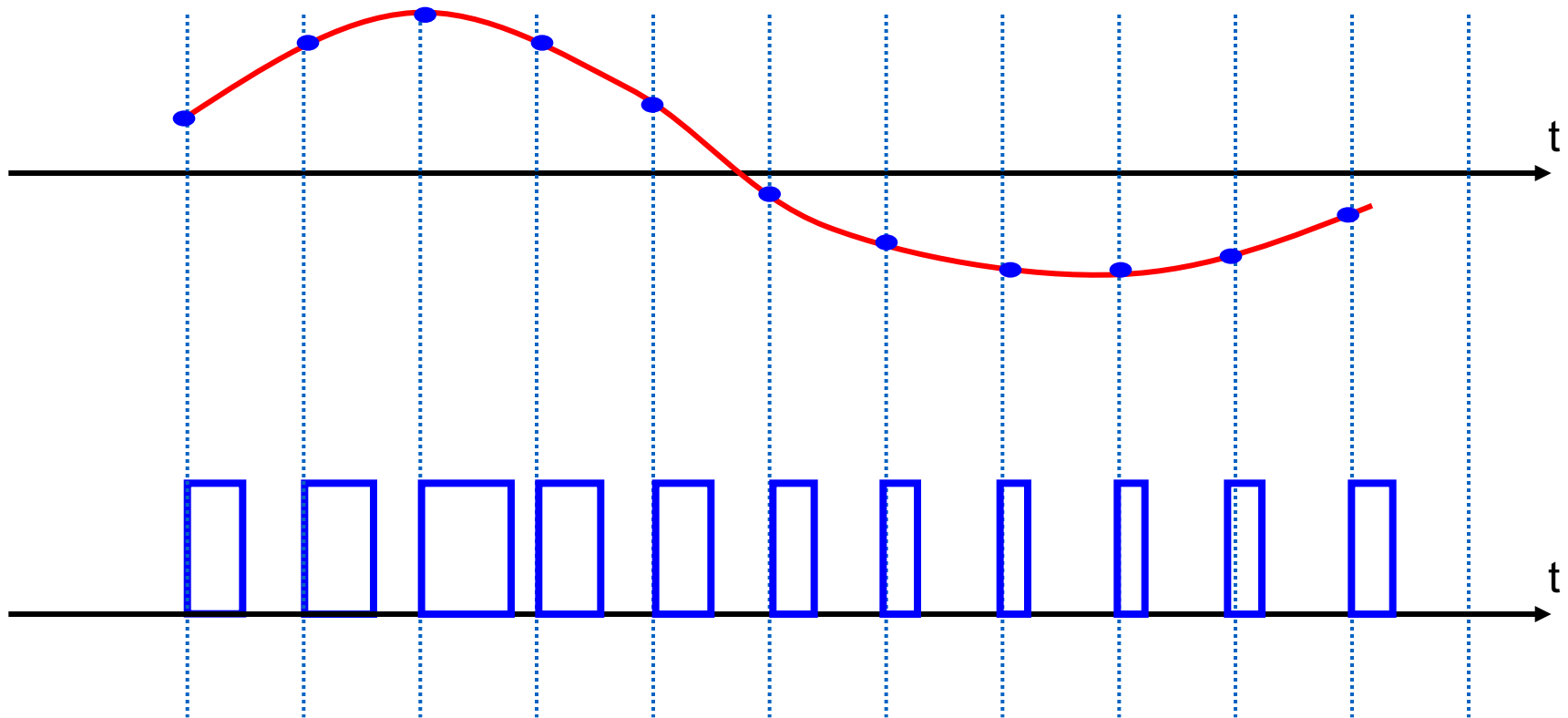

PPM

Q: How is PPM done?

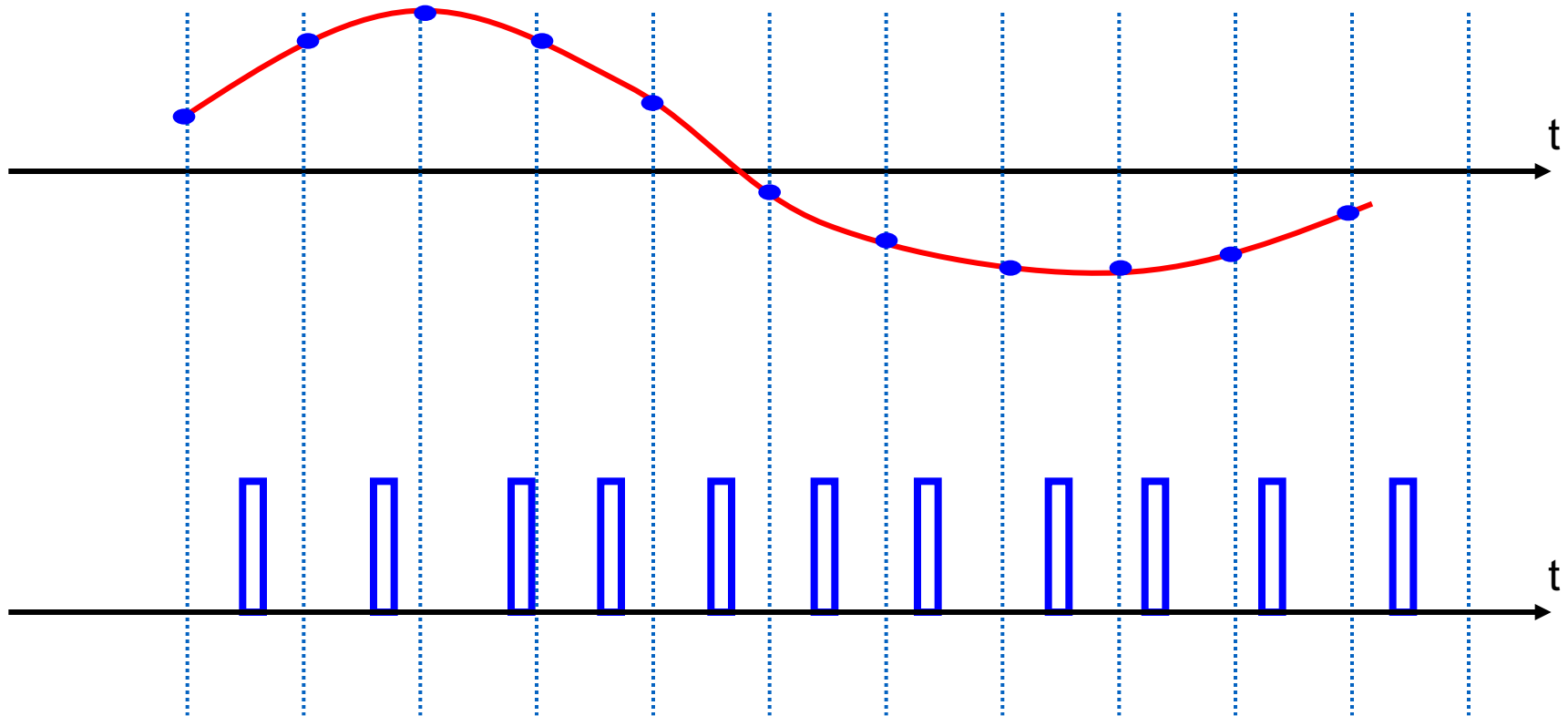

Time Division Multiplexing (TDM)

Time Division Multiplexing (TDM)

Q: What is time division multiplexing?

- We have seen that using PAM we can send the information by transmitting only samples of the message signal.
- If we short a very short pulse width in PAM there is sufficient space between the pulses to send other signals.
- This is called Time division multiplexing (TDM)

modulating (message) signal

